

# User manual



## Pipe Grinder

Type: AL100U-01 230V/400V

## Table of contents

1.	Foreword .....	4
1.1.	Name of machine .....	4
1.2.	Warning .....	4
1.3.	Target group for each chapter .....	4
1.4.	Symbols .....	4
1.5.	Re-ordering the user manual .....	4
1.6.	Deficiencies in this user manual .....	5
2.	Introduction .....	6
2.1.	The user .....	6
2.2.	The manufacturer .....	6
2.3.	Machine identification .....	6
2.4.	Function of the machine .....	7
2.5.	Machine options .....	7
2.6.	Liability .....	7
2.7.	Service .....	7
2.8.	Warranty conditions .....	7
3.	Safety regulations .....	8
3.1.	Safety provisions .....	8
3.1.1.	General .....	8
3.1.2.	Emergency stop .....	8
3.1.3.	Safety shields .....	8
3.2.	Warning symbols on the machine .....	9
3.3.	Safety regulations .....	10
3.4.	The operator .....	10
3.5.	The maintainer .....	10
3.6.	Setup of the machine .....	10
3.7.	The noise emission of the machine .....	11
3.8.	Maintenance of the machine .....	11
3.9.	Summary of the safety regulations .....	11
4.	Description .....	12
4.1.	General .....	12
4.2.	Construction of the machine .....	12
4.3.	Electrical supply .....	12
4.4.	Safety provisions and warning symbols .....	12
4.5.	Controls and adjustments .....	13
4.6.	Operation .....	14
4.6.1.	Starting and stopping the grinding belt .....	14
4.6.2.	Drive for the grinding belt .....	14
4.6.3.	Securing a tubing section .....	14
4.6.4.	Angle adjustment .....	14
4.6.5.	Stops .....	15
4.6.6.	Notching a tubing section .....	15
4.6.7.	Deburring .....	15
4.6.8.	Exchange of the grinding belt .....	15
4.6.9.	Exchange of the grinding roller .....	17
4.6.10.	Adjustment of the grinding roller and grinding belt .....	18
4.7.	Technical data .....	19
5.	Transport, storage, placement and initial setup .....	20
5.1.	Scope of delivery .....	20
5.2.	Assembly .....	21
5.3.	Placement of the machine .....	22
5.4.	Connection of the power supply .....	23
5.5.	Transport and storage .....	23
5.6.	Initial setup .....	24
6.	Operation .....	24
6.1.	Operation in general .....	24

6.2.	Start up.....	24
6.3.	Operation.....	24
6.4.	Shut down .....	25
7.	Maintenance .....	25
7.1.	Precautionary measures .....	25
7.2.	Checkpoints .....	25
7.3.	Replacement of components .....	26
8.	Trouble .....	26
8.1.	General information for trouble.....	26
8.2.	Trouble indications and signals .....	26
9.	Disposal.....	26
	EU Declaration of Conformity for machines .....	<b>Fout! Bladwijzer niet gedefinieerd.</b>
	The universal pipe notchers .....	<b>Fout! Bladwijzer niet gedefinieerd.</b>
	Table 1.3-1: Overview of the target groups for each chapter .....	4
	Table 4.7-1: Other available grinding roller diameters .....	20
	Table 4.7-2: Overview of recommended grinding belts.....	20
	Table 7.2-1: Checkpoints and lubrication schedule.....	25
	Figure 2.3-1: Sample type plate with CE-mark.....	6
	Figure 2.3-2: Location of the type plate .....	7
	Figure 3.1-1: Safety provisions.....	8
	Figure 3.2-1: Warning symbols on the machine.....	9
	Figure 4.2-1: Construction of the machine .....	12
	Figure 4.5-1: Controls and adjustments .....	13
	Figure 4.6-1: Deburring table.....	15
	Figure 4.6-2: Support for the grinding roller .....	16
	Figure 4.6-3: Belt-tensioning device .....	16
	Figure 4.6-4: Exchange of the grinding roller .....	17
	Figure 4.6-5: Adjustment of the centre height of the grinding roller .....	18
	Figure 4.6-6: Adjustment of the grinding roller in relation to the grinding belt.....	19
	Figure 4.7-1: Location of serial number.....	20
	Figure 5.2-1: Clarification of assembly .....	21
	Figure 5.2-2: Installation of the ball handle and handle .....	22
	Figure 5.4-1: Wiring connections in the connection compartment of the electrical motor.....	23
	Appendix:.....EU Declaration of Conformity for machines	
	Appendix:.....exploded view drawing 230 Volt with drawing number 04.00077	
	Appendix:.....exploded view drawing 400 Volt with drawing number 04.00078	

## 1. Foreword

*This foreword contains general information about and for this user manual.*

### 1.1. Name of machine

The name of the machine is "Universal pipe notcher".

### 1.2. Warning

Read this user manual carefully before use and before maintenance of the machine is carried out. Only then is optimal safety ensured. The machine may only be operated and maintained by personnel who have received special training.

There are moving parts on the machine!

For this reason, the machine must always be switched off and the electrical supply must be disconnected before maintenance and/or repairs are carried out.

Always be careful of the moving, sharp and/or protruding parts; they can cause injury!

### 1.3. Target group for each chapter

This user manual is intended to provide information to the persons/departments listed below.

- the owner
- the operator
- the maintainer

Next to the heading of each chapter is indicated for which of the groups described above the chapter is intended. Table 1.3-1 provides an overview of the target groups for each chapter.

Chapter	Title	Owner	Operator	Maintainer
-	Table of contents	•	•	•
1	Foreword	•	•	•
2	Introduction	•	•	•
3	Safety regulations	•	•	•
4	General description of the machine	•	•	•
5	Transport, storage and setup of the machine			•
6	Operation of the machine		•	•
7	Maintenance of the machine			•
8	Trouble		•	•
9	Disposal of the machine	•		•

**Table 1.3-1: Overview of the target groups for each chapter**

### 1.4. Symbols

The safety and caution symbols shown below are used in this document.



The information indicated by this symbol warns you of potential problems. Furthermore, the symbol warns you that you can seriously injure yourself or that you can seriously damage the machine.

### 1.5. Re-ordering the user manual

Extra copies of the user manual can be ordered from ALMI Machinefabriek BV of Vriezenveen. When ordering, indicate the document number and the number of copies. The document number is indicated in the footer area.

#### **1.6. Deficiencies in this user manual**

This user manual was prepared with the greatest possible care. Should you, nonetheless, find inaccuracies or deficiencies in the text, notify ALMI Machinefabriek BV of the problem.

## 2. Introduction

*This chapter provides basic information about the machine and the accompanying user manual. This chapter is intended for the owner, the operator and the maintainer of the machine.*

### 2.1. The user



Read this user manual carefully before use and before maintenance of the machine is carried out. Only then is optimal safety ensured.

The machine may only be operated by qualified personnel. The operator must read the chapters indicated in 1.3 carefully. Maintenance of the machine may only be carried out by specially trained personnel from the maintenance department. The maintainer must read the chapters indicated in 1.3 carefully.

### 2.2. The manufacturer

The manufacturer of the machine is:

ALMI Machinefabriek BV  
 Wierdenseweg 82-86  
 7671 JK Vriezenveen  
 The Netherlands  
 T+31(0)546 561 353  
 F+31(0)546 564 465

### 2.3. Machine identification

The machine is provided with the CE-mark. This is shown on the type plate. See Figure 2.3-1. The CE-mark indicates that this machine satisfies the fundamental health and safety requirements of the European Union. Also refer to the warning in section 1.2.

In addition to the CE-mark, the data indicated below is also shown on the type plate. See also Figure 2.3-1.

- Name and address of the manufacturer
- Type indication
- Year of manufacture
- Serial number (only reference)
- Required supply voltage
- Motor speed
- Weight

ALMI Machinefabriek B.V.		Motor specifications		
Type:	AL100U-01	Voltage:	400	
Year of manufacture:	2025	Hz:	50	
		1/min:	2895	
Serial no.: listed on the pipeclamp		Weight	190 kg	

**Figure 2.3-1: Sample type plate with CE-mark**

For the location of the attached CE-mark and type plate, see. Figure 2.3-2



**Figure 2.3.2: Location of the type plate**

**2.4. Function of the machine**

The function of the machine is the notching and/or deburring of the ends of tube sections. It is not permissible to use the machine for any other purpose.

**2.5. Machine options**

There is no optional equipment that can be added to the existing version of the machine to change its function.

**2.6. Liability**

When injury or harm to persons or damage to the machine or products is the result of not following these operating and maintenance instructions, ALMI Machinefabriek BV cannot be held liable.

**2.7. Service**

For service contact your dealer or your own maintenance department.

**2.8. Warranty conditions**

art. 1 If within 12 months of delivery ALMI Machinefabriek BV is notified of deficiencies in the delivered machine that are caused by defects in materials or workmanship and is provided with the serial number and the original receipt, ALMI will repair these defects.

art. 2 All warranty obligations expire if:

- repairs or modifications are made to the machine by others, without instruction from ALMI, in an incompetent manner;
- non-original parts are used;
- the damage or defects are the result of connecting the machine in a manner other than intended, incompetent use, or failure to follow the regulations and instructions for use;
- the deficiencies are the result of normal wear of the machine.

art. 3 ALMI reserves the right to have work on the machine carried out by third parties during and after the warranty period.

### 3. Safety regulations

*This chapter provides information concerning the general safety regulations. This chapter is intended for the owner, the operator and the maintainer of the machine. Read this chapter carefully before use of the machine and before carrying out repairs on the machine.*

#### 3.1. Safety provisions

##### 3.1.1. General

**For the exact location of the various provisions, see Figure 3.1-1.**

It is absolutely forbidden to remove or disable the safety provisions.

##### 3.1.2. Emergency stop

The machine is provide with an emergency stop. The emergency shall break the electrical supply. Unbreak the electrical supply by twisting the emergency stop counter clockwise, the emergency stop jumps back in starting point.

After pushing of the emergency stop the grinding belt will standstill.

##### 3.1.3. Safety shields

The grinding belt is enclosed in a housing that is only open on the front side at the location where the tube sections are notched.

For protection of the face, the location at which the tube sections are notched is equipped with a transparent, fold-away shield.

The deburring area is equipped with a cover.

In order to allow the replacement of the grinding roller and/or grinding belt, the housing is equipped with a side cover. The side cover must never be open or be opened when the grinding belt is in motion.

Only personnel that have received sufficient instruction may open safety shields to perform maintenance and/or repairs. Also refer to section 1.3 "Target group for each chapter".



**Figure 3.1-1: Safety provisions**



### 3.2. Warning symbols on the machine

The following warning symbols can be found on the machine. For the location of the warning symbols on the machine see Figure 3.2-1

It is absolutely forbidden to remove the warning symbols or make them unreadable by any means.

Worn warning symbols must be replaced in a timely manner.



**Pictogram 1:  
Read the user manual first!**



**Pictogram 2:  
Use of eye and hearing protection required!**



**Pictogram 3:  
Use of light respiratory protection required!**



**Pictogram 4:  
Use of safety gloves required!**

Pictograms 1 through 4



**Figure 3.2-1: Warning symbols on the machine**

### 3.3. Safety regulations

Although the machine satisfies the fundamental health and safety requirements of the European Union, dangerous situations can always occur. Always remain alert for possible dangerous situations. Be careful of projecting portions of the machine. Be careful with loose clothing and hair.

At a minimum, the following safety regulations must be followed:

- Never engage power to the machine if any person is in contact with the machine in a dangerous manner.
  - Never start the machine if any person is in contact with the machine in a dangerous manner.
  - During maintenance to the machine, switch off the machine and disconnect the electrical plug.
  - Follow the warnings and indications on the machine. For the explanation of the symbols, see section 3.2.
  - Before use of the machine, close the side cover.
  - Close the top cover if deburring is not required.
  - Use the fold-away shield to protect your face.
  - Wear close-fitting clothing during grinding work.
  - Before grinding, attach the workpiece securely.
  - No flammable materials may be present in the area surrounding the universal pipe notcher. The grinding of pipes creates showers of sparks.
  - Wear safety gloves during grinding operations, changing of the grinding roller and/or grinding belt, and during adjustment operations.
- Through intensive use, the roller can become extremely hot, and as a result of grinding, sharp burrs can be created.



**Always think of the safety of yourself and others!**

### 3.4. The operator

The machine may only be operated by personnel who are qualified to do so. Personnel that have this qualification are referred to in the rest of this user manual as the operator. As operator of the machine, you must be aware of the information that is relevant for you. Also refer to section 1.3 "Target group for each chapter". The operator is not permitted to perform operations that are not indicated to be intended for the operator. Comply with the safety regulations in this user manual. Do not deviate from the safety regulations. This can result in danger.

### 3.5. The maintainer

Only personnel from the maintenance department who have received special training may carry out maintenance of the machine. Personnel that have this qualification are referred to in the rest of this user manual as the maintainer. As maintainer of the machine, you must be aware of the information that is relevant for you. Also refer to section 1.3 "Target group for each chapter". Comply with the safety regulations in this user manual. Do not deviate from the safety regulations. This can result in danger.

### 3.6. Setup of the machine

Make sure that the machine is setup and properly anchored on a flat, horizontal floor during use.  
Make sure there is sufficient lighting to allow the work to be performed in a safe and responsible manner.

### **3.7. The noise emission of the machine**

The noise emission during grinding operations is 83-87 dB(A), measured at a distance of 1 metre. The use of good hearing protection is required.

### **3.8. Maintenance of the machine**

The machine must be in a sufficient state of repair that no dangerous situations can occur. The troubleshooting chart is provided in chapter 7. If replacement is necessary, use only original parts.

### **3.9. Summary of the safety regulations**

- The machine may only be operated by personnel who are qualified to do so.
- As operator of the machine, you must be aware of the information that is relevant for you. Also refer to section 1.3 "Target group for each chapter".
- The operator is not permitted to perform operations that are not indicated to be intended for the operator.
- Only personnel from the maintenance department who have received special training may carry out maintenance of the machine.
- As maintainer of the machine, you must be aware of the information that is relevant for you. Also refer to section 1.3 "Target group for each chapter".
- Always remain alert for possible dangerous situations. Be careful of projecting portions of the machine. Be careful with loose clothing and hair.
- Never engage power to the machine if any person is in contact with the machine in a dangerous manner.
- Never start the machine if any person is in contact with the machine in a dangerous manner.
- During maintenance to the machine, switch off the machine and disconnect the electrical plug.
- Follow the warnings and indications on the machine. For the explanation of the symbols, see section 3.2.
- Before use of the machine, close the side cover.
- Close the top cover if deburring is not required.
- Use the Lexan fold-away shield to protect your face.
- Wear close-fitting clothing during grinding work.
- Before grinding, attach the workpiece securely.
- No flammable materials may be present in the area surrounding the universal pipe notcher. The grinding of pipes creates showers of sparks.
- Wear safety gloves during grinding operations, changing of the grinding roller and/or grinding belt, and during adjustment operations.  
Through intensive use, the roller can become extremely hot, and as a result of grinding, sharp burrs can be created.

#### 4. Description

*This chapter provides general information about the machine. This chapter is intended for the owner, the operator and the maintainer of the machine.*

##### 4.1. General

This user manual includes an appendix with an exploded view drawing with drawing number 04.00077 & 04.00078.

This drawing includes a parts list containing the name of each part.

##### 4.2. Construction of the machine

**The machine consists primarily of the components shown in Figure 4.2-1.**



**Figure 4.2-1: Construction of the machine**

##### 4.3. Electrical supply

For the electrical connection, the machine is equipped with a 4-conductor supply cable without a plug. The machine is equipped with a "Euro-voltage" motor. This means that the motor can be connected to a 230 Volt, 3-phase or 400 Volt, 3-phase supply with a tolerance of  $\pm 10\%$ .

When the machine is connected for the first time, the voltage of the supply connection must be verified in comparison to the connection voltage indicated on the type plate and the correct plug must be installed. For the electrical connection, follow the instructions in section 5.6.

##### 4.4. Safety provisions and warning symbols

The safety provisions and warning symbols are handled in sections 3.1 and 3.2.

#### 4.5. Controls and adjustments

For regular operation, the machine has the following controls and adjustments. The controls and adjustments are shown in

Figure 4.5-1.

- a. Emergency stop
- b. Push button for stopping the grinding belt
- c. Push button for starting the grinding belt
- d. Ball wheel for adjusting support parallel to grinding roller
- e. Handle wheel for adjusting support perpendicular to grinding roller.
- f. Clamp handle for securing workpiece
- g. Allen bolt for securing rotatable clamp (using key with handle "j")
- h. Allen bolt for securing standard stopper (using key with handle "j")
- i. Allen bolt for securing grinding belt (using key with handle "j")
- j. Allen key, 8 mm, with handle; for securing rotatable tubing clamp, for securing standard stopper, and for adjustment of grinding belt
- k. Allen bolt for opening and closing side cover
- l. On – off switch

Controls and adjustments for changing and adjusting grinding belt and/or grinding roller are described in sections 4.6.8, 4.6.9 and 4.6.10.



Figure 4.5-1: Controls and adjustments

## 4.6. Operation

### 4.6.1. Starting and stopping the grinding belt

The switches for starting and stopping are on the right side of the support pillar. See figure

Figure 4.5-1.

To start the machine, push the green button.

To stop the machine, push the red button.

**ATTENTION! Before the machine is started, the side cover must be closed. The side cover is shown in Figure 3.1-1**

### 4.6.2. Drive for the grinding belt

The grinding belt is driven by a "Euro-voltage" motor. This means that the motor can be connected to a 230 Volt, 3-phase or 400 Volt, 3-phase supply with a tolerance of  $\pm 10\%$ .

Before first use, the voltage of the supply connection must be verified in comparison to the voltage indicated on the type plate. For the electrical connection, follow the instructions in section 5.6.

A pulley with a rubber coating is mounted on the motor shaft. The rubber coating, in combination with the correct belt tension, ensures the required grip of the grinding belt to the pulley.

Before putting tension on the grinding belt, see section 4.6.8.

The required direction of rotation is indicated on the pulley. Consider this when making the electrical connection. For the electrical connection, follow the instructions in section 5.6.

The direction of rotation is also indicated on the inside of the grinding belt. This must match the arrow on the pulley.

Before installation of the grinding belt, see section 4.6.8.

### 4.6.3. Securing a tubing section

For working, the tubing section must be secured in the tubing clamp.

**The tubing clamp is mounted on the cross support. See**

Figure 4.5-1.

The tubing clamp with V-shaped side plates is suitable for clamping tubing with a diameter of 18 - 76 mm.

When the V-shaped side plates are removed, the tubing clamp can also be used to secure rectangular- and square-profile tubing. In the case of rectangular- and square-profile tubing, the centre of the tubing profile must be at the same height as the centre of the grinding roller. To achieve the correct height of the tubing profile, a fill block can be used under the tubing section.

**The clamp can be secured with the clamp handle on the tubing clamp. See**

Figure 4.5-1.

### 4.6.4. Angle adjustment

To adjust the angle, Allen head bolt "g" must be loosened.

The scale divisions allow the correct angle to be set.

In relation to the grinding roller, the clamp is adjustable from 90 to 30 degrees.

After adjustment, the Allen bolts "g" must be re-tightened.

#### 4.6.5. Stops

**Under the cross support of the tubing clamp is a clamp block "h" with which a standard stopper can be adjusted. See**

Figure 4.5-1. The stopper works to prevent the movement of the support toward the grinding roller. The stopper can be secured with an Allen bolt.

**The flat side of the clamp has two M8-threaded holes. See**

Figure 4.5-1. A length stopper can be attached to these.

The stoppers are designed to ensure that a series of tubing sections with the same dimensions are notched to an equal depth.

The length stopper is not included with the machine and must be made by the user.

#### 4.6.6. Notching a tubing section

After the tubing section has been clamped and the correct angle and stoppers are set up, the slide with ball handle "d" must be positioned so the tubing section that is to be notched is moved toward the centre of the grinding roller. Handle "e" is used to adjust the support perpendicular to the grinding roller. By moving the support toward the grinding roller, the tubing section can be notched. Care must be given to ensure that the width of the notch does not exceed the width of the grinding belt.

#### 4.6.7. Deburring

**The top of the machine is equipped with a deburring table for deburring the notched tubing section. See Figure 4.6-1. For deburring, the top cover must be opened. The cover is shown in figure 3.1-1.**



**Figure 4.6-1: Deburring table**

#### 4.6.8. Exchange of the grinding belt

Before the grinding belt is exchanged, the machine must be disconnected from the electrical supply by removing the plug connection from the mains supply. Also read the safety regulations in section 3.3.

Wear safety gloves during exchange of the grinding roller and/or grinding belt. Through intensive use, the roller can become extremely hot.

**To create the room that is necessary for exchange of the grinding belt, the support must be moved as far as possible from the grinding roller with handle "e". Handle "e" is shown in**

Figure 4.5-1.

To gain access to the grinding belt, the side cover and the top cover must be opened. The covers are shown in Figure 3.1-1

To remove the belt, the tension on the belt must be released and the support for the grinding roller must be released.

The belt tension can be released by turning the hand crank counter-clockwise. The position of the belt-tension device is shown in Figure 4.2-1. The belt-tension mechanism with hand crank is shown in Figure 4.6-3.

The support for the grinding roller can be released by loosening the wingnuts. The support is shown in Figure 4.6-2.

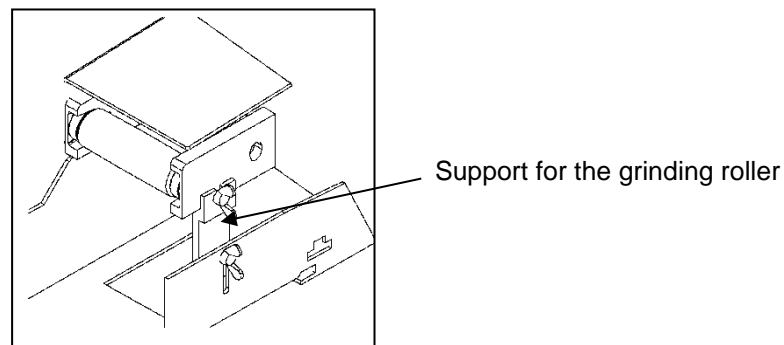

**Figure 4.6-2: Support for the grinding roller**

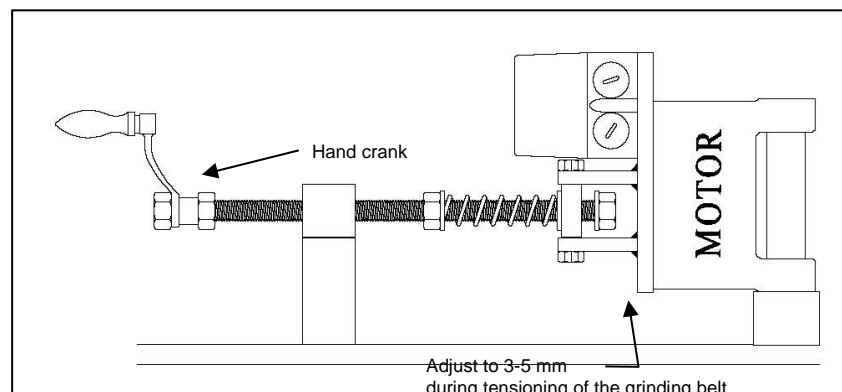

**Figure 4.6-3: Belt-tensioning device. The grinding belt can now be removed.**

Remove all remnants.

During installation of a new grinding belt, the required direction of rotation for the belt must match that of the pulley. An arrow is shown on both the inside of the belt and the pulley. Begin by placing the new grinding belt on the side of the grinding roller. For correct selection of a grinding belt, see section 4.7.

**ADVICE:** For a grinding roller with a diameter smaller than 30 mm, use a grinding belt that has previously been used on a roller with a larger diameter. A new grinding belt is very stiff and may break if used on a grinding roller with a small diameter.



After installing the new grinding belt, the belt must be tensioned properly. This can be done by turning the hand crank clockwise until the area between the ring and the plate is 3-5 mm. See Figure 4.6-3. The tension is determined by the degree to which the spring is compressed.

Next, the support for the grinding roller must be moved back to its original position and secured with the wingnuts. See Figure 4.6-2.

After exchange of the grinding belt, any misalignment of the belt must be corrected. For more information, see section 4.6.10.

#### 4.6.9. Exchange of the grinding roller

Before the grinding roller is exchanged, the machine must be disconnected from the electrical supply by removing the plug connection from the mains supply. Also read the safety regulations in section 3.3.

Wear safety gloves during exchange of the grinding roller and/or grinding belt. Through intensive use, the roller can become extremely hot.

Before the grinding roller is exchanged, the grinding belt must be removed. For more information, see section 4.6.8.

The grinding roller is held in place by two spring-pressure retainers. The grinding roller can be easily removed from the holder as shown in Figure 4.6-4.

Never adjust the spring-pressure retainers. They have been properly adjusted by the manufacturer.

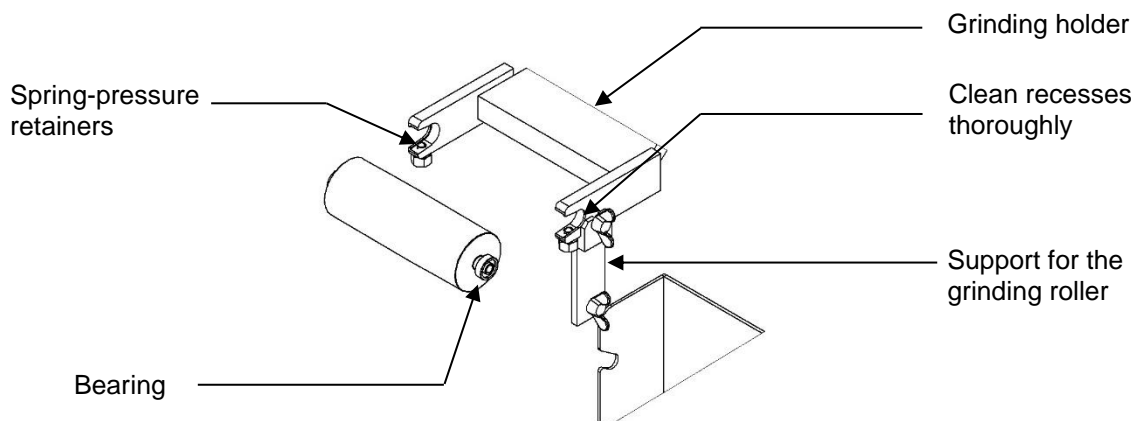

**Figure 4.6-4: Exchange of the grinding roller**

Before the new grinding roller is installed, the recesses of the support for the grinding roller must be cleaned thoroughly. This prevents clamping problems.

Thereafter, the new grinding roller can be installed.

The grinding belt can also be re-installed. For more information, see section 4.6.8.

For an overview of the available grinding-roller diameters, see section 4.7.

**ADVICE:** For a grinding roller with a diameter smaller than 30 mm, use a grinding belt that has previously been used on a roller with a larger diameter. A new grinding belt is very stiff and may break if used on a grinding roller with a small diameter.

ATTENTION! The bearings that are mounted on the grinding roller must be handled with care because they can be easily damaged.

After exchange of the grinding roller, any misalignment (diagonal running) of the belt must be corrected. For more information, see section 4.6.10.

#### 4.6.10. Adjustment of the grinding roller and grinding belt

During first use, see chapter 5, and after exchange of the grinding belt and/or grinding roller, the adjustment of the grinding roller and the grinding belt must always be checked.

The centre of the grinding roller must be at the same height as the centre of the tubing, and the belt may not run diagonally during operation.

Before the grinding roller is adjusted, the machine must be disconnected from the electrical supply by removing the plug connection from the mains supply. Also read the safety regulations in section 3.3.

Wear safety gloves during adjustment operations. Through intensive use, the roller can become extremely hot.

Before adjustment, the two wingnuts of the support for the grinding roller, see Figure 4.6-2, must be loosened one turn.

##### Adjustment of the centre height:

The height is adjusted as well as possible by the manufacturer. If the centre of the tubing profile is not at the same height as the centre of the grinding roller, the height of the grinding roller must be adjusted. For more information, see Figure 4.6-5.

After loosening bolts "R", the height of the grinding roller can be adjusted. After adjustment, re-tighten bolts "R".

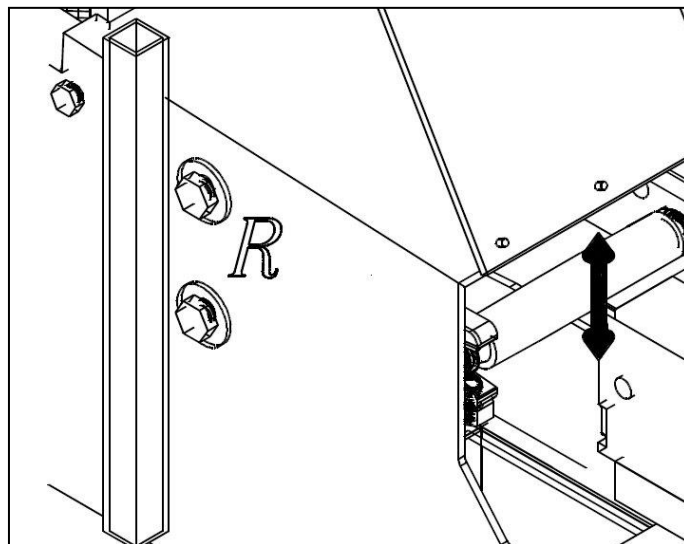
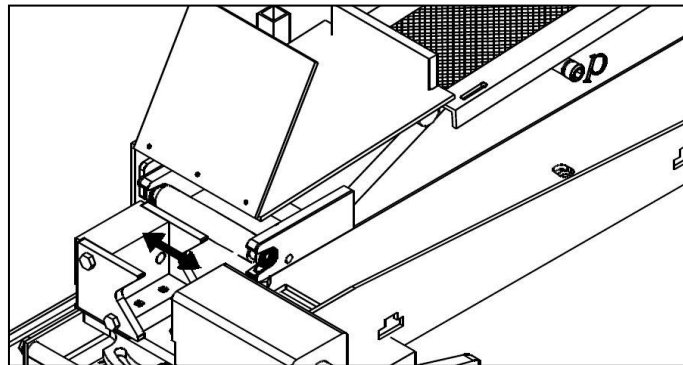

Figure 4.6-5: Adjustment of the centre height of the grinding roller

### Adjustment of the grinding roller in relation to the grinding belt

For adjustment of the grinding roller in relation to misalignment of the grinding belt, see also Figure 4.6-6.



**Figure 4.6-6: Adjustment of the grinding roller in relation to the grinding belt**

Turn bolt P in either direction until the misalignment has been corrected. For a rough adjustment, the grinding belt should be driven by hand (by turning the drive roller on the motor shaft). For fine adjustment, the motor can be switched on.

**ATTENTION! First close the side cover! See Figure 3.1-1**

Comply with the safety regulations in section 3.3.

ATTENTION! After adjustment, the two wingnuts of the support for the grinding roller, see Figure 4.6-2, must be re-tightened.

#### 4.7. Technical data

Type:	AL100U-01
Serial number	Is indicated on the top of the clamp. See Figure 4.7-1.
Weight	190 kg
Measurements	l <sub>x</sub> w <sub>x</sub> h=1450x1150x650 mm
Motor	Squirrel-cage armature motor SG100L-21, 3 kW, suitable for supply voltage of 230 V or 400 V. Motor speed: 2895 rpm at 400V/50Hz 3420 rpm at 230V/60Hz The motor includes thermal protection and a switch with a no-voltage coil.
Versions of motor switches and no-voltage coils	Voltage 230 V: - switch PKZM1-10 - no-voltage coil U-PKZM1-230 Voltage 400 V: - switch PKZM1-6 - no-voltage coil U-PKZM1-400
Belt speed	30 m/s at 400V/50Hz 36 m/s at 230V/60Hz
Notching depth	20-76 mm
Grinding roller	For available grinding roller diameters, see Table 4.7-1
Grinding belt	Measurements: l <sub>x</sub> w=2000x100 mm (79"x4") The machine is delivered standard with 2 grinding belts, 1 type R929 and 1 type R996 both grit K36 For recommended grinding belts, see Table 4.7-2
Noise emission	83-87 dB(A) measured at a distance of 1 metre from the machine.

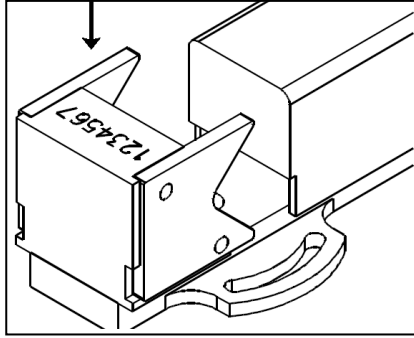

**Figure 4.7-1: Location of serial number.**

Range 20-60 mm diameter	diameters increasing in steps of 2 mm
Special diameters	76 mm, 1/2", 3/4", 1", 1 1/4", 1 1/2" and 2"
Other diameters between 20 and 76 mm	Other diameters are available from your dealer upon request.

**Table 4.7-1: Other available grinding roller diameters**

Grinding roller diameter	Steel		Stainless steel		Aluminium	
	type	grit	type	grit	type	grit
20 through 40 mm	R929	36	R929	36	R929	36
40 through 76 mm	R996	36	R996	36	R996	36

**Table 4.7-2: Overview of recommended grinding belts**

## 5. Transport, storage, placement and initial setup

*This chapter provides information about the scope of delivery, transport, storage, placement and initial setup of the machine. This chapter is intended for the maintainer of the machine.*

### 5.1. Scope of delivery

The machine is delivered in a wooden crate.

The following loose components are included in the scope of delivery:

part	quantity	description
1	1	Universal pipe notcher
2	1	Foot plate
3	1	Support pillar
4	2	Hex bolt with washer M12
5	1	Grinding waste container (in the support pillar)
6	1	Ball handle (in the support pillar)
7	1	Handle (in the support pillar)
8	2	Grinding belt (in the support pillar)
9	1	Allen key, 8 mm, with handle
10	1 Set	Attachment hardware (in the support pillar)
11	1	Power supply cable without plug
12	1 Set	Grinding rollers and belts (if ordered separately)
13	1	User manual
14	1	exploded view drawing with drawing number 3.1008.000

## 5.2. Assembly

For clarification of the procedures below, see also Figure 5.2-1.

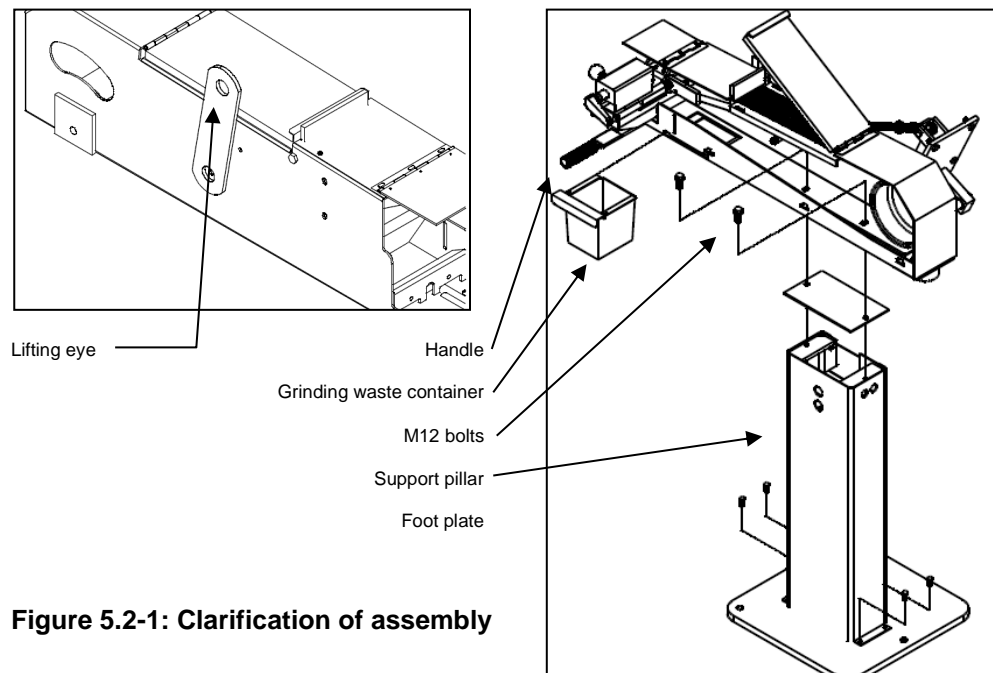

**Figure 5.2-1: Clarification of assembly**

- Remove loose components from the packaging.  
Inside the support pillar you will find a box with any ordered grinding belts and grinding rollers, the grinding waste container, the ball handle, the handle and the attachment hardware.
- Remove the two attachment bolts with which the universal pipe notcher is attached to the bottom plate of the packaging.
- Remove the wood screws with which the support pillar and foot plate are attached to the crate.
- Remove the support pillar from the packaging and attach them together.  
**ATTENTION!** Inside the support pillar you will find a box with any ordered grinding belts and grinding rollers, the grinding waste container, the ball handle, the handle and the attachment hardware.
- Remove the machine from the packaging. To do so, use the lifting eye. Use the proper lifting equipment. The machine weighs 200 kg.
- Open the side cover of the machine.  
Attach the machine to the support pillar using two M12 hex bolts.
- Slide the grinding waste container under the machine.
- Install the included ball handle on the front of the cross support.
- Install the included handle under the cross support.

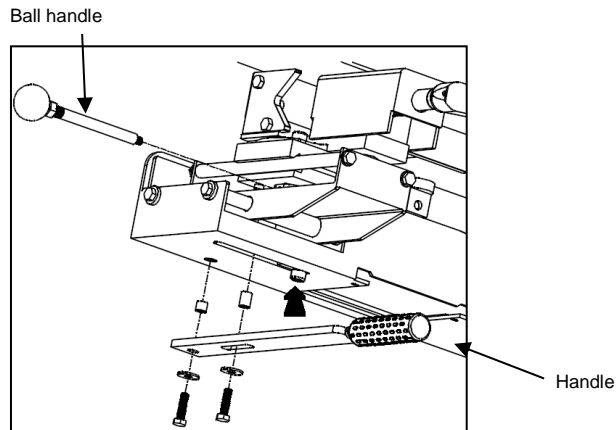

**Figure 5.2-2: Installation of the ball handle and handle**

- To test the direction of rotation and for adjustment during the initial setup, also install a grinding roller and a grinding belt. See sections 5.4 and 5.6. For the installation of the grinding belt and the grinding roller, see sections 4.6.8 and 4.6.9.

### **5.3. Placement of the machine**

Make sure that the machine is setup and properly anchored on a flat, horizontal floor during use.

Make sure there is sufficient lighting to allow the work to be performed in a safe and responsible manner.

#### 5.4. Connection of the power supply

For the electrical connection, a 4-conductor supply cable without a plug is supplied with the machine. The machine is equipped with a "Euro-voltage" motor. This means that the motor can be connected to a 230 Volt, 3-phase or 400 Volt, 3-phase supply with a tolerance of  $\pm 10\%$ .

The voltage of the supply connection must be verified in comparison to the connection voltage indicated on the type plate.

If the voltages are not the same, the adaptations described below must be made.

- Open the connection compartment of the electrical motor and install the strips as shown in Figure 5.4-1.
- Replace the motor switch and the no-voltage coil. Section 4.7 shows what is required.
- Replace the type plate of the machine.

The motor switch, the no-voltage coil and the type plate are available through your dealer.

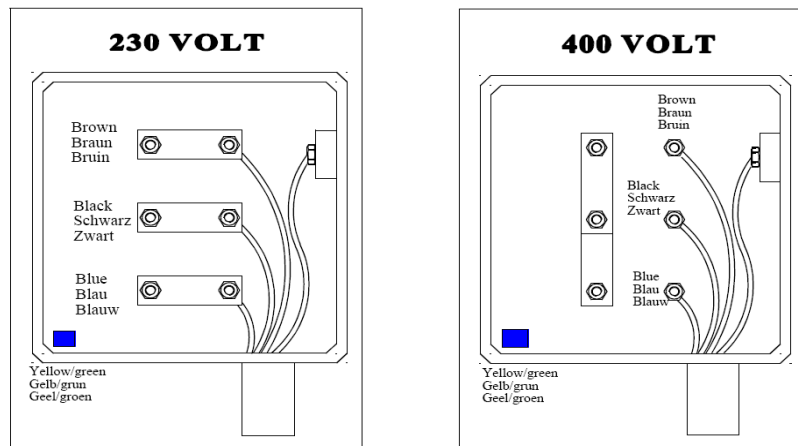

**Figure 5.4-1: Wiring connections in the connection compartment of the electrical motor**

Connect the wiring of the supply cable according to the correct diagram in Figure 5.4-1. Install a plug that matches your electrical outlet on the end of the cable. After connection, check the direction of rotation of the grinding belt. The top surface must move toward the cross support.

**ATTENTION! First close the side cover! See Figure 3.1-1.**

Comply with the safety regulations in section 3.3.

If necessary, exchange the concerned wires in the plug.

Route the cable to the electrical outlet in such a manner that it will not be tripped over.

#### 5.5. Transport and storage

The machine is delivered in a wooden crate. The crate can be lifted and moved with a forklift.

Once the machine has been assembled, it is sensible to lay the machine on a pallet when it must be moved or stored.

It can then be moved with a forklift.

For vertical lifting, the machine is also equipped with a lifting eye. This lifting eye can be used to set the machine upright.

## 5.6. Initial setup

During first use and after exchange of the grinding belt and/or grinding roller, the adjustment of the grinding roller and the grinding belt must always be checked. The centre of the grinding roller must be at the same height as the centre of the tubing, and the belt may not run diagonally during operation.

For the adjustment procedures, see the description in section 4.6.10.

Once the machine is plugged into the mains supply, the machine is ready for use.

## 6. Operation

*This chapter provides information about the operation of the machine. This chapter is intended for the operator and the maintainer of the machine.*

### 6.1. Operation in general

The following is a description of regular operation.

Comply with the safety regulations in chapter 3.

Operation is carried out using the controls and adjustments described in section 4.5.

For additional information also see section 4.6, the "Operation" of the machine.

### 6.2. Start up

- Connect the machine to the mains supply, if it is not already connected.
- Check whether the correct grinding belt is installed. For selection of the proper grinding belt, see Table 4.7-2. Check the grinding belt for wear. If it is necessary to replace the grinding belt, see section 4.6.8.
- Check whether the correct grinding roller is installed. The correct grinding roller is determined by the diameter measurement of the tubing sections that must be connected to one another. For available grinding roller diameters, see Table 4.7-1. If it is necessary to replace the grinding roller, see section 4.6.9.
- Check the adjustment of the grinding roller and the grinding belt. The centre of the grinding roller must be at the same height as the centre of the tubing, and the belt may not run diagonally during operation. For the adjustment procedures, see the description in section 4.6.10.
- Check whether the grinding waste container must be emptied.

### 6.3. Operation

- Before securing rectangular- or square-profile tubing, remove the side plates from the clamp. If necessary, use a fill block to maintain the correct centre height of the tubing section. See also section 4.6.3.
- Secure the tubing section in the tubing clamp.
- Set the proper angle. Tighten the clamp.
- Bring the tubing section toward the centre of the grinding roller.
- Start the machine. To do so, push the green button on the motor switch.
- Move the tubing section toward the grinding roller for notching. The width of the notch must not exceed the width of the grinding belt.
- To notch a series of tubing sections that have the same diameter and length, the stoppers can be used. For more information, see section 4.6.5.
- After notching the tubing section, it can be deburred on the deburring table at the top of the machine. To do so, open the top cover.
- Stop the machine. To do so, push the red button on the motor switch.



**6.4. Shut down**

The machine can be shut down by removing the plug from the mains connection.

**7. Maintenance**

*This chapter provides information about the maintenance of the machine. This chapter is intended for the maintainer of the machine.*

**7.1. Precautionary measures**



Maintenance of the machine may only be performed if the machine is voltage free. Comply with the safety regulations in chapter 3.

**7.2. Checkpoints**

The machine must regularly be checked according to the points in Table 7.2-1. Replace components as necessary. See section 7.3.

Item number	Description	Time interval
1	Check the presence and proper operation of safety shields. See section 3.1. Check the operation of the closing mechanism for the side cover. Check the visibility through the transparent shield above the grinding roller	Monthly
2	Check the presence and legibility of the warning symbols. See section 3.2. Worn or removed symbols must be replaced.	Monthly
3	Check for wear of the grinding-roller bearings. See also section 4.6.9.	Every 6 months
4	Check the operation of the tubing clamp, bolts and screw threads used to secure and adjust a tubing section. See also sections 4.6.3, 4.6.4 and 4.6.5.	Every 6 months
5	Check the wear of the rubber coating on the drive roller. The coating ensures the proper grip of the grinding belt to the drive unit. See also section 4.6.2.	Every 6 months
6	Check the proper operation of the belt-tensioning device. See also section 4.6.8.	Every 6 months
7	Check the operation of the adjustment mechanism for the grinding roller. See also section 4.6.10.	Every 6 months
8	Thoroughly clean the machine on a regular basis.	Monthly
9	Check the mains cable for damage.	Monthly

**Table 7.2-1: Checkpoints and lubrication schedule**

### 7.3. Replacement of components

If the machine requires repair, we recommend that you contact your dealer. If you carry out repairs yourself, you must only use original parts.

When ordering parts, the following information must be provided:

- The machine type number,  
The machine type number is indicated on the type plate.
- The machine serial number;  
The machine serial number is indicated on the top of the clamp. See Figure 4.7-1.
- The part number,  
The part number is indicated on the exploded view drawing provided with this user manual, drawing number 04.00077 & 04.00078.

## 8. Trouble

*This chapter provides information about trouble and trouble indications. This chapter is intended for the operator and the maintainer of the machine.*

### 8.1. General information for trouble

When trouble occurs, switch off the machine and contact your dealer or your own maintenance department.

Comply with the instructions in chapter 3 and the maintenance instructions in chapter 7.

### 8.2. Trouble indications and signals

The machine controls do not include trouble indications or other signals.

## 9. Disposal

*This chapter provides information about the disposal of the machine. This chapter is intended for the owner and the maintainer of the machine.*

The machine must be disposed of in accordance with the legal requirements of the country in which it is used.

The owner is responsible for disposal of the machine.

## EU Declaration of Conformity

ALMI Machinefabriek BV  
Wierdenseweg 82-86  
7671 JK Vriezenveen  
The Netherlands

This declaration of conformity is issued for:

Product name	<b>Pipe Grinder</b>
Type Number	<b>AL100U-01</b>
Serial Number of AL100U-01 covered by this EU DoC	<b>YY31008 (YY = 20 or higher, 31008 = Drawing number)</b>

We, ALMI Machinefabriek BV, declare under our sole responsibility that the above mentioned product(s) conform to the essential requirements of the following European Union directives:  
The object of the declaration described above is in conformity with the following regulations:

<b>Machine Directive (MD)</b>	2006/42/EC
<b>Low Voltage Directive (LVD)</b>	2014/35/EU
<b>Electromagnetic Compatibility (EMC) Directive</b>	2014/30/EU

The following harmonized standards and normative documents are those to which the product's conformance is declared, and by specific reference to the essential requirements of the referenced Directives:

<b>Health and Safety (MD Annex 1, section 1)</b> <b>Safety of machinery –</b> <b>General principles for design –</b> <b>Risk assessment and risk reduction</b> <b>(ISO 12100:2010)</b>	NEN-EN-ISO 12100:2010
--	-----------------------

<b>Health and Safety (LVD Annex 1)</b>  <b>Safety of machinery - Electrical equipment of</b> <b>machines - Part 1: General requirements</b>	NEN-EN-IEC 60204-1:2018
--	-------------------------

01-01-2025, Vriezenveen, The Netherlands

Signed for on behalf of ALMI Machinefabriek BV



S. Jansen  
General Director