

User manual



Pipe notcher

Type: AL 1-2U

Table of contents

- 1. Foreword 4
 - 1.1. Name of machine 4
 - 1.2. Warning 4
 - 1.3. Target group for each chapter 4
 - 1.4. Symbols 4
 - 1.5. Re-ordering the user manual 5
 - 1.6. Deficiencies in this user manual 5
- 2. Introduction 6
 - 2.1. The user 6
 - 2.2. The manufacturer 6
 - 2.3. Machine identification 6
 - 2.4. Function of the machine 7
 - 2.5. Machine options 7
 - 2.6. Liability 7
 - 2.7. Service 7
 - 2.8. Warranty conditions 7
- 3. Safety regulations 8
 - 3.1. Safety provisions 8
 - 3.1.1. General 8
 - 3.1.2. Emergency stop 8
 - 3.1.3. Safety shields 8
 - 3.2. Warning symbols on the machine 9
 - 3.3. General safety regulations 9
 - 3.4. The operator 10
 - 3.5. The maintainer 10
 - 3.6. Setup of the machine 10
 - 3.7. The noise emission of the machine 10
 - 3.8. Maintenance of the machine 10
 - 3.9. Summary of the safety regulations 11
- 4. Description 12
 - 4.1. General 12
 - 4.2. Construction of the machine 12
 - 4.3. Electrical supply 12
 - 4.4. Safety provisions and warning symbols 12
 - 4.5. Controls and adjustments 12
 - 4.6. Operation 13
 - 4.6.1. Starting and stopping the machine 13
 - 4.6.2. Drive for the machine 13
 - 4.6.3. Notching 14
 - 4.7. Technical data 15
- 5. Scope of delivery, transport, storage, placement and initial setup 15
 - 5.1. Scope of delivery 15
 - 5.2. Unpacking 16
 - 5.3. Placement of the machine 16
 - 5.4. Connection of the power supply 16
 - 5.5. Transport and storage 17
 - 5.6. Initial setup 17
- 6. Operation 18
 - 6.1. Operation in general 18
 - 6.2. Start up 18
 - 6.3. Operation 18
 - 6.4. Shut down 18
- 7. Maintenance 18
 - 7.1. Precautionary measures 19
 - 7.2. Checkpoints and lubrication schedule 19

7.3.	Replacement of components	19
7.3.1.	Replacement of a punch and/or spring	19
7.3.2.	Housing replacement	21
8.	Trouble	22
8.1.	General information for trouble	22
8.2.	Trouble indications and signals	22
9.	Disposal	22
	EU Declaration of Conformity for machines	Fout! Bladwijzer niet gedefinieerd.
Table 1.3.1: Overview of the target groups for each chapter		4
Table 7.2.1: Checkpoints and lubrication schedule		19
Figure 2.3-1: Sample type plate		6
Figure 2.3-2: Location of the type plate		7
Figure 3.1-1: Safety provisions		8
Figure 3.2-1: Warning symbols on the machine		9
Figure 4.2-1: Construction of the machine		12
Figure 4.5-1: Controls and adjustments		13
Figure 4.6-1: Tube diameters for notching		14
Figure 5.2-1: Position of hoisting strap (the AL1-2E is shown)		16
Figure 5.4-1: Wiring connections in the connection compartment of the electrical motor		17
Figure 6.1-1: Lubrication		18
Figure 7.3-1: Replacement of a punch and/or spring 1		20
Figure 7.3-2: Replacement of a punch and/or spring 2		20
Appendix:		EU Declaration of Conformity for machines
Appendix:		exploded view drawing with drawing number 03.00008
Appendix:		exploded view drawing with drawing number 03.00009

1. Foreword

This foreword contains general information about and for this user manual.

1.1. Name of machine

The name of the machine is "Pipe notcher".

1.2. Warning

Read this user manual carefully before use and before maintenance of the machine is carried out. Only then is optimal safety ensured. The machine may only be operated and maintained by personnel who have received special training.

There are moving parts on the machine!

For this reason, the machine must always be switched off and the electrical supply must be disconnected before maintenance and/or repairs are carried out.

Always be careful of the moving, sharp and/or protruding parts; they can cause injury!

1.3. Target group for each chapter

This user manual is intended to provide information to the persons/departments listed below.

- the owner
- the operator
- the maintainer

Next to the heading of each chapter is indicated for which of the groups described above the chapter is intended. Table 1.3.1 provides an overview of the target groups for each chapter.

Chapter	Title	Owner	Operator	Maintainer
-	Table of contents	•	•	•
1	Foreword	•	•	•
2	Introduction	•	•	•
3	Safety regulations	•	•	•
4	General description of the machine	•	•	•
5	Transport, storage and setup of the machine			•
6	Operation of the machine		•	•
7	Maintenance of the machine			•
8	Trouble		•	•
9	Disposal of the machine	•		•

Table 1.3.1: Overview of the target groups for each chapter

1.4. Symbols

The safety and caution symbols shown below are used in this document.



The information indicated by this symbol warns you of potential problems. Furthermore, the symbol warns you that you can seriously injure yourself or that you can seriously damage the machine.

1.5. Re-ordering the user manual

Extra copies of the user manual can be ordered from ALMI Machinefabriek BV of Vriezenveen. When ordering, indicate the document number and the number of copies. The document number is indicated in the footer area.

1.6. Deficiencies in this user manual

This user manual was prepared with the greatest possible care. Should you, nonetheless, find inaccuracies or deficiencies in the text, notify ALMI Machinefabriek BV of the problem.

2. Introduction

This chapter provides basic information about the machine and the accompanying user manual. This chapter is intended for the owner, the operator and the maintainer of the machine.

2.1. The user



Read this user manual carefully before use and before maintenance of the machine is carried out. Only then is optimal safety ensured.

The machine may only be operated by qualified personnel. The operator must read the chapters indicated in 1.3 carefully. Maintenance of the machine may only be carried out by specially trained personnel from the maintenance department. The maintainer must read the chapters indicated in 1.3 carefully.

2.2. The manufacturer

The manufacturer of the machine is:

ALMI Machinefabriek BV
 Wierdenseweg 82-86
 7671 JK Vriezenveen
 The Netherlands
 T+31(0)546 561 353
 F+31(0)546 564 465

2.3. Machine identification

The machine is provided with the CE-mark. This is shown on the type plate. See Figure 2.3-1.

The CE-mark indicates that this machine satisfies the fundamental health and safety requirements of the European Union. Also refer to the warning in section 1.2.

In addition to the CE-mark, the data indicated below is also shown on the type plate. See also Figure 2.3-1.

- Name and address of the manufacturer
- Type indication
- Year of manufacture
- Serial number (only reference)
- Required supply voltage
- Speed of reduction motor output shaft
- Weight

ALMI Machinefabriek B.V.		Motor specifications		
Type:	AL 1-2U	Voltage:	400	
Year of manufacture:	2025	Hz:	50	
		1/min:	30	
Serial no.: listed on the housing		Weight	92 kg	

Figure 2.3-1: Sample type plate

For the location of the attached CE-mark and type plate, see Figure 2.3-2.



Figure 2.3-2: Location of the type plate

2.4. Function of the machine

The function of the machine is the notching of tube ends to facilitate perpendicular welding of tube constructions.

It is forbidden to use the machine for purposes other than the notching of pipes with the specified diameter.

2.5. Machine options

There is no optional equipment that can be added to the existing version of the machine to change its function.

2.6. Liability

When injury or harm to persons or damage to the machine or products is the result of not following these operating and maintenance instructions, ALMI Machinefabriek BV cannot be held liable.

2.7. Service

For service contact your dealer or your own maintenance department.

2.8. Warranty conditions

art. 1 If within 12 months of delivery ALMI Machinefabriek BV is notified of deficiencies in the delivered machine that are caused by defects in materials or workmanship and is provided with the serial number and the original receipt, ALMI will repair these defects.

art. 2 All warranty obligations expire if:

- repairs or modifications are made to the machine by others, without instruction from ALMI, in an incompetent manner;
- non-original parts are used;
- the damage or defects are the result of connecting the machine in a manner other than intended, incompetent use, or failure to follow the regulations and instructions for use;
- the deficiencies are the result of normal wear of the machine.

art. 3 ALMI reserves the right to have work on the machine carried out by third parties during and after the warranty period.

3. Safety regulations

This chapter provides information concerning the general safety regulations. This chapter is intended for the owner, the operator and the maintainer of the machine. Read this chapter carefully before use of the machine and before carrying out repairs on the machine.

3.1. Safety provisions

3.1.1. General

For the exact location of the various provisions, see Figure 4.2-1.
It is absolutely forbidden to remove or disable the safety provisions.

3.1.2. Emergency stop

The machine is provide with an emergency stop. The emergency shall break the electrical supply. Unbreak the electrical supply by twisting the emergency stop counter clockwise, the emergency stop jumps back in starting point.

3.1.3. Safety shields

The machine has no moving external parts.

Access to the moving parts is restricted by a safety shield.

Only personnel that have received sufficient instruction may open the safety shield to perform maintenance and/or repairs. Also refer to section 1.3 "Target group for each chapter".

Safety shield



Figure 3.1-1: Safety provisions

3.2. Warning symbols on the machine

The following warning symbols can be found on the machine. For the location of the warning symbols on the machine see Figure 3.2-1

It is absolutely forbidden to remove the warning symbols or make them unreadable by any means.

Worn warning symbols must be replaced in a timely manner.



Pictogram 1: Read the user manual first!

Pictogram 1



Figure 3.2-1: Warning symbols on the machine

3.3. General safety regulations

Although the machine satisfies the fundamental health and safety requirements of the European Union, dangerous situations can always occur. Always remain alert for possible dangerous situations. Be careful of projecting portions of the machine.

At a minimum, the following safety regulations must be followed:

- Never engage power to the machine if any person is in contact with the machine in a dangerous manner.
- Never start the machine if any person is in contact with the machine in a dangerous manner.
- During maintenance to the machine, switch off the machine and disconnect the electrical plug.
- Follow the warnings and indications on the machine. For the explanation of the symbols, see section 3.2.
- Wear safety gloves during notching operations. Sharp burrs on the tube ends can result from notching operations.



Always think of the safety of yourself and others!

3.4. The operator

The machine may only be operated by personnel who are qualified to do so. Personnel that have this qualification are referred to in the rest of this user manual as the operator. As operator of the machine, you must be aware of the information that is relevant for you. Also refer to section 1.3 “Target group for each chapter”. The operator is not permitted to perform operations that are not indicated to be intended for the operator. Comply with the safety regulations in this user manual. Do not deviate from the safety regulations. This can result in danger.

3.5. The maintainer

Only personnel from the maintenance department who have received special training may carry out maintenance of the machine. Personnel that have this qualification are referred to in the rest of this user manual as the maintainer. As maintainer of the machine, you must be aware of the information that is relevant for you. Also refer to section 1.3 “Target group for each chapter”. Comply with the safety regulations in this user manual. Do not deviate from the safety regulations. This can result in danger.

3.6. Setup of the machine

The machine must be firmly anchored in a horizontal position. Ensure a proper working height for the insertion of tube sections. Make sure there is sufficient lighting to allow the work to be performed in a safe and responsible manner.

3.7. The noise emission of the machine

The noise emission during notching is ≤ 70 dB(A). No special hearing protection is required.

3.8. Maintenance of the machine

The machine must be in a sufficient state of repair that no dangerous situations can occur. The troubleshooting chart is provided in chapter 7. Use only original parts.

3.9. Summary of the safety regulations

- The machine may only be operated by qualified personnel.
- As operator of the machine, you must be aware of the information that is relevant for you in these operation and maintenance regulations. Refer to section 1.3 "Target group for each chapter".
- The operator is not permitted to perform operations that are not indicated to be intended for the operator.
- As maintainer of the machine, you must be aware of the information that is relevant for you in these operation and maintenance regulations. Refer to section 1.3 "Target group for each chapter".
- Always remain alert for possible dangerous situations. Be careful of projecting portions of the machine. Be careful with loose clothing and hair.
- Never engage power to the machine if any person is in contact with the machine in a dangerous manner.
- Never start the machine if any person is in contact with the machine in a dangerous manner.
- During maintenance to the machine, switch off the machine and disconnect the electrical plug.
- Follow the warnings and indications on the machine. For the explanation of the symbols, see section 3.2.
- It is absolutely forbidden to remove the warning symbols or make them unreadable by any means. Worn warning symbols must be replaced in a timely manner.
- The machine must be in a sufficient state of repair that no dangerous situations can occur. The troubleshooting chart is provided in chapter 7.
- Only sufficiently trained personnel may open protective shields to perform service. Also refer to section 1.3 "Target group for each chapter".

4. Description

This chapter provides general information about the machine. *This chapter is intended for the owner, the operator and the maintainer of the machine.*

4.1. General

This user manual includes an appendix with an exploded view drawing with drawing number AL 1-2-U.

This drawing includes a parts list containing the name of each part.

4.2. Construction of the machine

The machine consists primarily of the components shown in **Figure 4.2-1**.

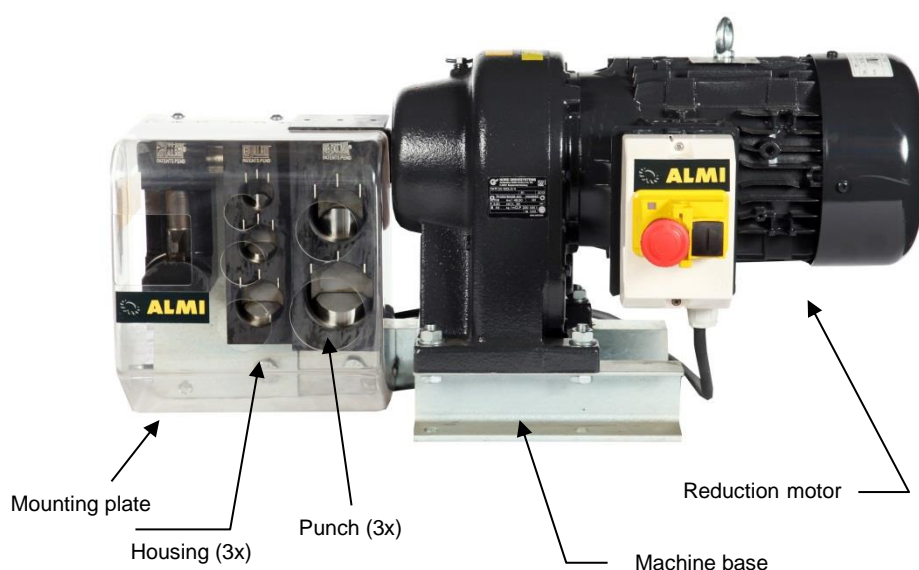

Figure 4.2-1: Construction of the machine

4.3. Electrical supply

For the electrical connection, the machine is equipped with a 4-conductor supply cable without a plug. The machine is equipped with a "Euro-voltage" motor. This means that the motor can be connected 220 to 240 Volt, 3-phase or 380 to 460 Volt, 3-phase supply.

When the machine is connected for the first time, the voltage of the supply connection must be verified in comparison to the connection voltage indicated on the type plate and the correct plug must be installed. For the electrical connection, follow the instructions in section 5.4.

4.4. Safety provisions and warning symbols

The safety provisions and warning symbols are handled in sections 3.1 and 3.1.

4.5. Controls and adjustments

For operation, the machine has the following controls. The controls and adjustments are shown in Figure 4.5-1.

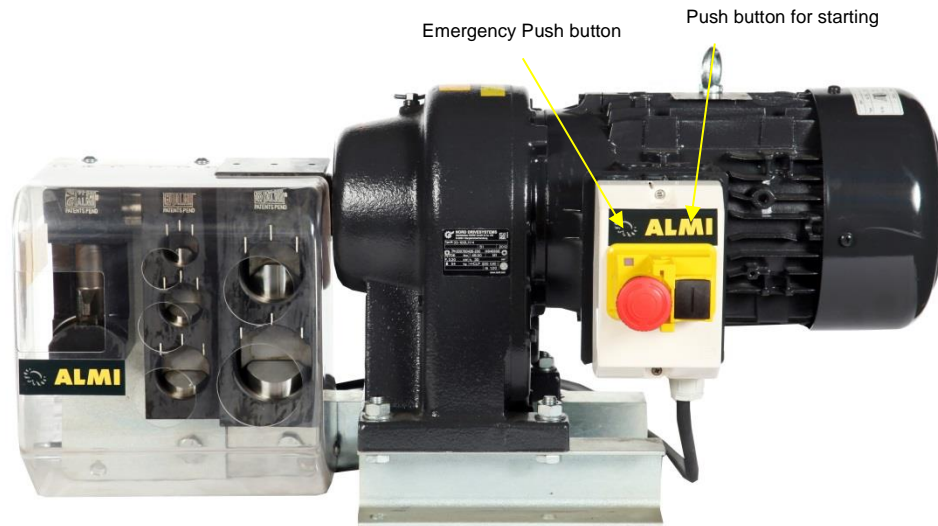

Figure 4.5-1: Controls and adjustments

4.6. Operation

4.6.1. Starting and stopping the machine

The switches for starting and stopping are on the electric motor of the machine. See figure 4.5-1.

To start the machine, push the black button.

To stop the machine, push the red button.

4.6.2. Drive for the machine

The machine is driven by a "Euro-voltage" motor.

This means that the motor can be connected 220 to 240 Volt, 3-phase or 380 to 460 Volt, 3-phase supply.

Before first use, the voltage of the supply connection must be verified in comparison to the voltage indicated on the type plate.

The required direction of rotation is indicated on the motor. Consider this when making the electrical connection. For the electrical connection, follow the instructions in section 5.4.

The reduction motor is manufactured with a hollow shaft. An eccentric shaft is mounted inside. The eccentric shaft rotates in the punch housing. The shaft has positions for two housings with punches. When the motor is running, the punches are moved up and down by the eccentrics and punch springs.

4.6.3. Notching

The square hole is for notching a sink outflow, see Figure 4.6-1. and is suitable for both round and square tubes.

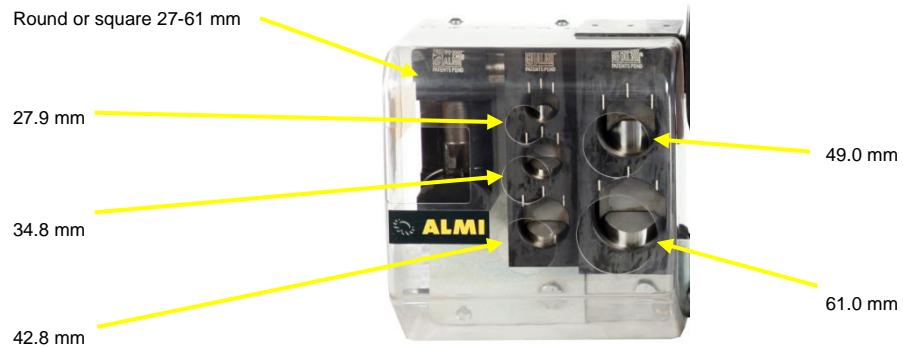

Figure 4.6-1: Tube diameters for notching

The maximum wall thickness of the tube is 5 mm.

To notch the tube, it must be inserted in the appropriate hole. While notching, the tube must be held with a bit of pressure. The notching occurs on the underside of the tube. When it is necessary to also notch the top side of the tube, the tube must be retracted, turned 180° and inserted into the hole again.

ATTENTION! Wear safety gloves during notching operations. Sharp burrs on the tube ends can result from notching operations.

4.7. Technical data

Type:	AL 1-2U
Serial number	Is indicated on the side of each punch housing. Each housing has its own serial number.
Weight	73 kg
Reduction motor	SK33-100LH/4, 2.2 Kw, suitable for supply voltage of 220 to 240 V Output speed of reduction motor: 30 rpm at 50Hz 36 rpm at 60Hz suitable for supply voltage of 380 to 460 V Output speed of reduction motor: 30 rpm at 50Hz 36 rpm at 60Hz The motor includes thermal protection and a switch with a no-voltage coil.
Versions of motor switches and no-voltage coils	Voltage 230 V: - switch PKZM1-10 - no-voltage coil U-PKZM1-230 Voltage 400 V: - switch PKZM1-6 - no-voltage coil U-PKZM1-400
Tube diameters (ext.)	Unit AL1: Ø27.9, Ø34.8, Ø42.8 Unit AL2: Ø49.0 en 61.0 Unit ALU: round or square 27-61 mm
Tube wall thickness	Maximum 5 mm.
Noise emission	≤70 dB(A)

5. Scope of delivery, transport, storage, placement and initial setup

This chapter provides information about the scope of delivery, transport, storage, placement and initial setup of the machine. This chapter is intended for the maintainer of the machine.

5.1. Scope of delivery

The machine is delivered in a wooden crate.

The following loose components are included in the scope of delivery:

part	quantity	description
1	1	Pipe notcher
3	1	Power supply cable without plug
4	1	User manual
5	1	“exploded view” drawing with drawing number AL 1-2-U

5.2. Unpacking

- Remove the two attachment bolts with which the pipe notcher is attached to the bottom plate of the packaging.
- Remove the pipe notcher from the packaging with a hoisting strap placed around the motor. See Figure 5.2-1.

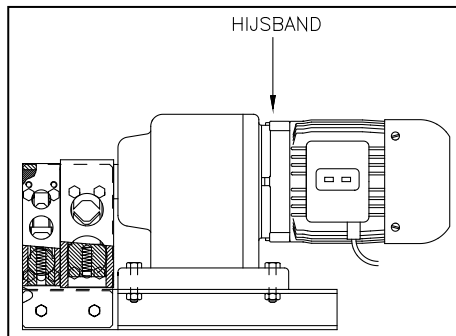

Figure 5.2-1: Position of hoisting strap (the AL1-2E is shown)

5.3. Placement of the machine

The machine must be firmly anchored in a horizontal position. Ensure a proper working height for the insertion of tube sections. Make sure there is sufficient lighting to allow the work to be performed in a safe and responsible manner.

5.4. Connection of the power supply

For the electrical connection, the machine is equipped with a 4-conductor supply cable **without** a plug. The machine is equipped with a "Euro-voltage" motor. This means that the motor can be connected 220 to 240 Volt, 3-phase or 380 to 460 Volt, 3-phase supply.

The voltage of the supply connection must be verified in comparison to the connection voltage indicated on the type plate.

If the voltages are not the same, the adaptations described below must be made.

- Open the connection compartment of the electrical motor and install the strips as shown in Figure 5.4-1.
- Replace the motor switch and the no-voltage coil. Section 4.7 shows what is required.
- Replace the type plate of the machine.

230 V

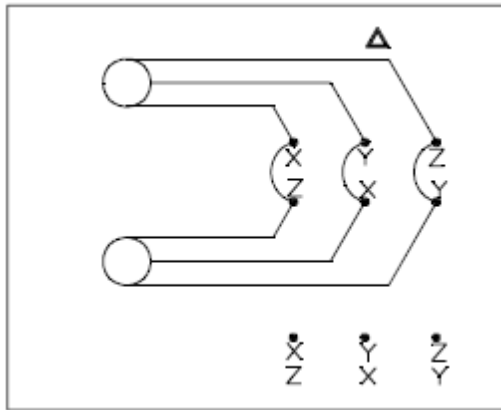

400 V

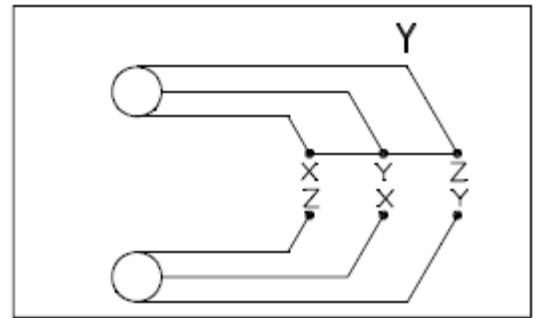

X= Rood	Y= Zwart	Z= Oranje
Red	Black	Orange
Rot	Schwarz	Orange

Figure 5.4-1: Wiring connections in the connection compartment of the electrical motor

The motor switch, the no-voltage coil and the type plate are available through your dealer.

Install a plug that matches your electrical outlet on the end of the cable. After connection, check the direction of rotation of the motor. The required direction of rotation is indicated on the motor.

If necessary, exchange the concerned wires in the plug.

Route the cable to the electrical outlet in such a manner that it will not be tripped over.

5.5. Transport and storage

The machine is delivered in a wooden crate. The crate can be placed on a pallet so it can be lifted and moved with a forklift.

Once the machine has been assembled, it is sensible to lay the machine on a pallet when it must be moved or stored.

It can then be moved with a forklift.

For vertical lifting with a hoist, a hoisting strap must be installed as shown in Figure 5.2-1.

5.6. Initial setup

The machine is ready for use when all of the procedures relating to unpacking, setup and electrical connection are complete. See sections 5.2, 5.2 and 5.2.

6. Operation

This chapter provides information about the operation of the machine. This chapter is intended for the operator and the maintainer of the machine.

6.1. Operation in general

The following is a description of operation.

Operation is carried out using the controls and adjustments described in section 4.5.

For more information concerning operation, also see section 4.6.

The machine may only be operated by personnel who have received sufficient instruction.

Lubricate the eccentric shaft every day before the machine is put in use.

During continual use of the pipe notcher, the eccentric shaft must be lubricated every half hour. Drip the oil in the 3 holes provided for this purpose. See Figure 6.1-1. Use lubricating oil MOLYKOTE M55 PLUS.

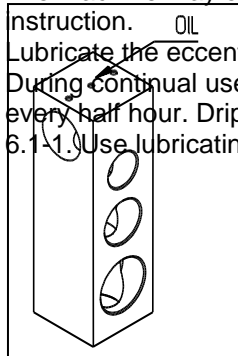

Figure 6.1-1: Lubrication

6.2. Start up

Connect the machine to the mains supply, if it is not already connected.
The machine is now ready for use.

6.3. Operation

- a. Push the black push button to start the machine.
- b. To punch a sink outflow, insert the tube in the square opening of the pipe notcher and hold the tube with a bit of pressure.
- c. As soon as the notch is made to the underside of the pipe, you must retract the pipe again.
- d. When you are finished punching, stop the machine by pushing the red push button.

6.4. Shut down

The machine can be shut down by removing the plug from the mains connection.

7. Maintenance

This chapter provides information about the maintenance of the machine. This chapter is intended for the maintainer of the machine.

7.1. Precautionary measures



Maintenance of the machine may only be performed if the machine is voltage free. Comply with the safety regulations in chapter 3.

7.2. Checkpoints and lubrication schedule

Periodically, the procedure in Table 7.2.1 must be carried out. Replace components as necessary. See section 7.3.

Item number	Description	Time interval
1	Check the presence and proper operation of safety shields. See section 3.1.	Monthly
2	Check the presence and legibility of the warning symbols. See section 3.2. Worn or removed symbols must be replaced.	Monthly
3	Check the machine for wear. Check primarily for wear to the punch.	Monthly
4	Lubricate the eccentric shaft. Drip the oil in the 3 holes provided for this purpose. See Figure 6.1-1. Use lubricating oil MOLYKOTE M55 PLUS.	Monthly
5	Check the plug and cable for damage.	Monthly

Table 7.2.1: Checkpoints and lubrication schedule

7.3. Replacement of components

If the machine requires repair, we recommend that you contact your dealer. If you carry out repairs yourself, you must only use original parts.

When ordering parts, the following information must be provided:

- The machine type number,
The machine type number is indicated on the type plate.
- The serial number for ordering a housing for a punch unit,
The serial number for a housing is indicated on its left side.
- The part number,
The part number is indicated on the exploded view drawing provided with this user manual, drawing number AL 1-2U.

7.3.1. Replacement of a punch and/or spring

Before replacement of the punch or spring, the plug must be removed from the mains outlet.

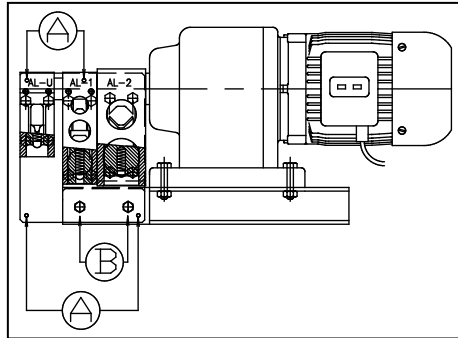

Figure 7.3-1: Replacement of a punch and/or spring 1

Remove the safety shield by removing bolts A (M6 x 10). See

Figure 7.3-1.

Remove the mounting plate and the intermediate strip that are attached to the U-beam with two bolts B (1x M12 x 40 and 1x M12 x 50). See

Figure 7.3-1.

Turn the mounting plate, to which the housings are attached, 180° around the eccentric shaft so the underside of the housings face upward. See Figure 7.3-2.

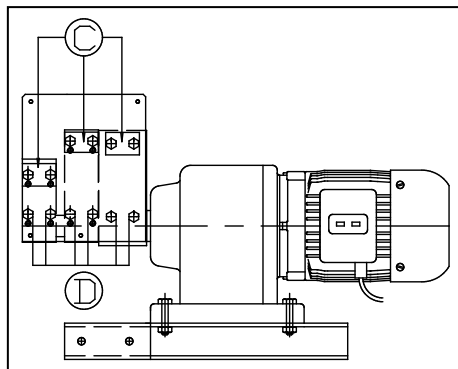

Figure 7.3-2: Replacement of a punch and/or spring 2

ATTENTION! Never turn the adjustment bolts (uppermost bolts) D of the housing. They have been properly adjusted by the manufacturer.

Move the punch to the position in which the spring is not under tension. Remove the spring support by loosening the two bolts C (M10 x 40). Now remove the spring and/or the punch. Install the punch and/or spring in the reverse order.

ATTENTION! If the spring support is not mounted straight, the punch will jam.

While tightening the two bolts B that secure the mounting plate and the intermediate strip, it is a good idea to let the machine run so it adjusts itself and you can see whether the machine runs properly. See figure 7.3-1.

ATTENTION! While you let the machine run, do not place your fingers in any of the punch housing holes.

If the procedure described above is not followed and this results in faulty assembly, we cannot provide coverage under the warranty.

7.3.2. Housing replacement

First remove all punches and springs as described in section 7.3.1.

Remove the uppermost hex bolts from the concerned housing and loosen the adjustment bolts.

Remove the housing from the eccentric shaft.

Next, install the new housing.

Screw in the two bottommost hex bolts. **ATTENTION:** do not tighten them.

When you replace an ALU housing, you must use M10 x 30 bolts instead of the M10 x 40 bolts that are normally installed in the machine.

When you replace an AL1 housing, you must use M10 x 30 bolts instead of the M10 x 40 bolts that are normally installed in the machine.

When you replace an AL2 housing, you must use M10 x 20 bolts instead of the M10 x 30 bolts that are normally installed in the machine.

You must tighten the bolts so the top and bottom of the housing are equidistant from the mounting plate.

The space between the ALU housing and the mounting plate and the between the AL1 housing and the mounting plate is usually 1-2 mm.

When you replace an AL1 housing you must push it against the AL2 housing.

When you replace an AL2 housing you must push it against the AL1 housing.

When you replace an ALU housing, this is not important.

Tighten the two bottommost bolts evenly and firmly against the housing.

Make sure the housings rotate smoothly around the shaft.

Tighten the two uppermost adjustment bolts evenly and firmly against the housing. **Make sure the housings rotate smoothly around the shaft.**

Screw in the two uppermost hex bolts.

Make sure the housings rotate smoothly around the shaft.

Screw in the two bottommost hex bolts.

Make sure the housings rotate smoothly around the shaft.

Once the housings turn smoothly around the shaft, remove the bottommost hex bolts from the housing that you are replacing.

ATTENTION: the housings must still rotate smoothly around the shaft.

Now re-install the punches, springs and spring supports. See section 7.3.1.

Install again with the original hex bolts.

After assembly, let the machine run for about an hour for testing.

ATTENTION: the housings must not become warm.

When replacing a housing, always indicate the serial number shown on the left side of the housing.

If the procedure described above is not followed and this results in faulty assembly, we cannot provide coverage under the warranty.

8. Trouble

This chapter provides information about trouble and trouble indications. This chapter is intended for the operator and the maintainer of the machine.

8.1. General information for trouble

When trouble occurs, switch off the machine and contact your dealer or your own maintenance department.

Comply with the instructions in chapter 3 and the maintenance instructions in chapter 3.

8.2. Trouble indications and signals

The machine controls do not include trouble indications or other signals.

9. Disposal

This chapter provides information about the disposal of the machine. This chapter is intended for the owner and the maintainer of the machine.

The machine must be disposed of in accordance with the legal requirements of the country in which it is used.

The owner is responsible for disposal of the machine.

EC Declaration of Conformity

ALMI Machinefabriek BV
Wierdenseweg 82-86
7671 JK Vriezenveen
The Netherlands

This declaration of conformity is issued for:

Product name **Pipe Notcher**
Type Number(s) **AL 1-2U**

We, ALMI Machinefabriek BV, declare under our sole responsibility that the above mentioned product(s) conform to the essential requirements of the following European Union directives:

The object of the declaration described above is in conformity with the following regulations:

Machine Directive (MD)	2006/42/EC
Low Voltage Directive (LVD)	2014/35/EU
Electromagnetic Compatibility (EMC) Directive	2014/30/EU

The following harmonized standards and normative documents are those to which the product's conformance is declared, and by specific reference to the essential requirements of the referenced Directives:

Health and Safety (MD Annex 1, section 1)

Safety of machinery – General principles for design – Risk assessment and risk reduction (ISO 12100:2010)	NEN-EN-ISO 12100:2010
--	-----------------------

Health and Safety (LVD Annex 1)

Safety of machinery - Electrical equipment of machines - Part 1: General requirements	NEN-EN-IEC 60204-1:2018
--	-------------------------

Issued on 01-01-2025, Vriezenveen, The Netherlands

Signed for on behalf of ALMI Machinefabriek BV



S. Jansen
General Director